



Features

- Dual Flush System
- Water Saving

Specifications

Water Use : 6L / 3L
 Water Pressure : 0.05MPa~0.75MPa

Parts description

- **WH171A**
 Concealed Tank (6L / 3L)

Optional Parts

- MB174P
 Flush Panel
- MB170P
 Flush Panel
- MB176G
 Flush Panel

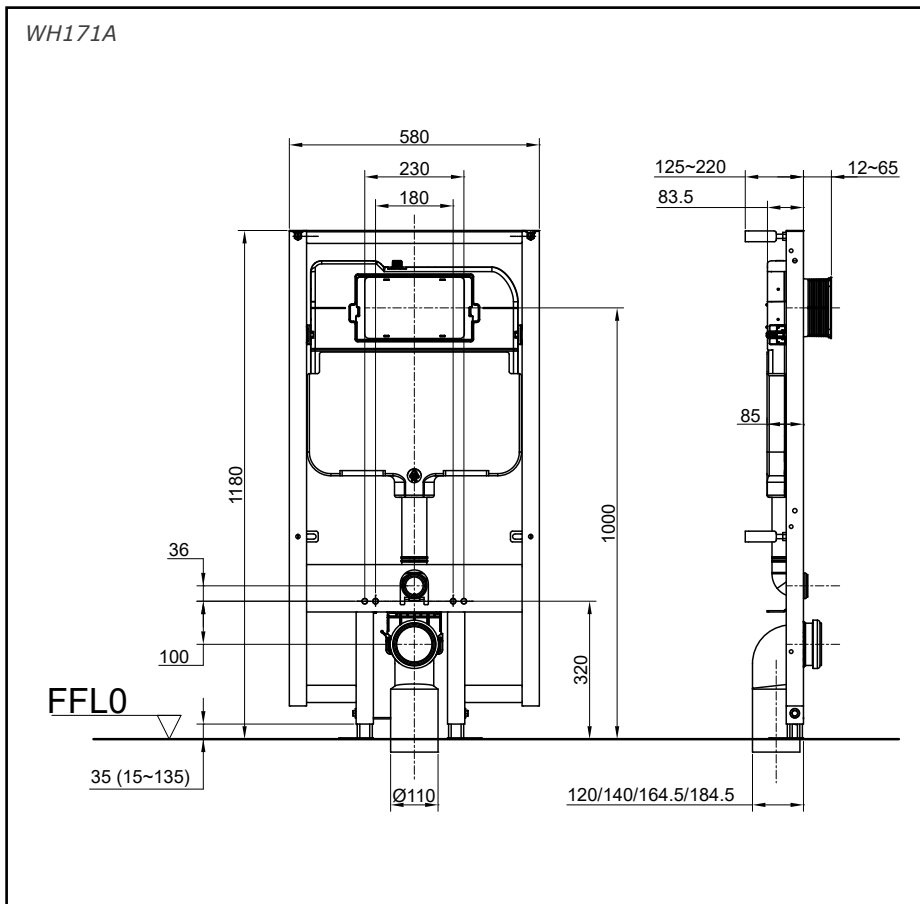

Please consult a TOTO representative for details